

The LIGA Technique and Its Potential for Microsystems—A Survey

Walter Bacher, Wolfgang Menz, and Jürgen Mohr

Abstract—The LIGA technique which is being developed at the Research Center Karlsruhe offers the possibility to manufacture microstructures with arbitrary lateral geometry, lateral dimensions down to below $1\ \mu\text{m}$ and aspect ratios up to 500 from a variety of materials (metals, plastics, and ceramics). The basic steps of X-ray lithography, electroplating, and plastic molding, are briefly described. Examples of applications of the LIGA technique are: optical components (high performance microspectrometer), mechanical components (acceleration sensor with integrated temperature compensation), and fluidic components (micropumps) which are presented and discussed. Microcomponents will be of limited interest in the future if it will not be possible to integrate them into microsystems. Microsystems must be more powerful than the sum total of their components. This is discussed in the final chapter of this article.

I. INTRODUCTION—THE BASIC CONCEPTS OF THE LIGA TECHNIQUE

THE motivation for the development of microsystems engineering can be seen in the application of the concepts of microelectronics to mechanics, optics, and fluidics while trusting that the same enhancement in performance accompanied by a reduction in cost can be achieved as in microelectronics. However, attention should be paid to an essential difference between a microelectronic circuit and a mechanical microstructure: Whereas the first generally extends in two dimensions only (the lateral extension is greater by orders of magnitude than the vertical one), techniques had to be developed for microstructure generation which also allow the third dimension of a structure to be shaped.

While the means of lateral pattern generation had been taken over from microelectronics in the form of photolithography, mostly with minor modifications, the individual techniques differ mainly by the methods applied to shape the third dimension.

Also the LIGA technique, which had been developed at the Nuclear Research Center Karlsruhe (KfK), now Research Center Karlsruhe (FzK), Institute for Microstructure Technology (IMT) [1] and is continuously being improved and expanded, benefits from the technological potential of microelectronics. However, compared with silicon-based microengineering, it offers some major technological advantages which will be explained in more detail below.

Manuscript received September 9, 1994; revised April 22, 1995.

The authors are with Forschungszentrum Karlsruhe GmbH, Institut für Mikrostrukturtechnik, D-76021 Karlsruhe, Germany.

IEEE Log Number 9413754.

II. THE LIGA TECHNIQUE

The manufacture of a LIGA microstructure is represented schematically in Fig. 1. Unlike in the silicon-based technology, the source material is a polymeric plastic layer of several hundred micrometers thickness which is applied onto a substrate, most frequently a metallic base plate. The X-ray sensitive polymer is directly polymerized onto the base plate. Until now, polymethyl methacrylate (PMMA) has almost exclusively been used as X-ray resist. The pattern of a mask is transferred into the thick resist layer by means of highly parallel, high intensity, and high energy synchrotron radiation at a characteristic wavelength of 0.2–0.6 nm.

Due to breakage in the long chains of molecules, the irradiated areas change their chemical stability and can be dissolved with a suitable developer. Techniques involving microelectrodeposition are applied successively to build up a complementary structure of metal, e.g., copper, gold, nickel, and nickel alloys so far while filling the gaps of the electrically nonconducting resist. With the metal structure so generated, almost any number of copies in plastic can be reproduced with high accuracy in detail and at relatively little cost using either injection molding, reaction injection molding, or vacuum embossing techniques [2]. For this, the metallic microstructure is used as the mold insert which is filled with the material to be molded. After demolding, these plastic structures also can be transferred into the complementary metal structure by electrodeposition or serve as “lost molds” for the manufacture of ceramic microstructures.

These main process steps have given the technique its name, LIGA, a German acronym consisting of the letters LI (RöntgenLithographie meaning X-ray lithography), G (Galvanik meaning electrodeposition), and A (Abformung meaning molding).

A. Mask Making

Deep-etch X-ray lithography is the first and most important step within the LIGA process. Pattern transfer into thick resists calls for the use of high energy synchrotron radiation ($\lambda_c = 0.2 - 0.6\ \text{nm}$) and masks with a high X-ray contrast. In order to achieve a contrast of more than 200, very thick absorbers with high atomic numbers and highly transparent mask blanks with low atomic numbers are needed. During one typical lithography step, the masks are exposed to X-ray radiation with a dose of about $1\ \text{MJ}/\text{cm}^2$. The mask has to withstand many exposures without any distortions or radiation damages.

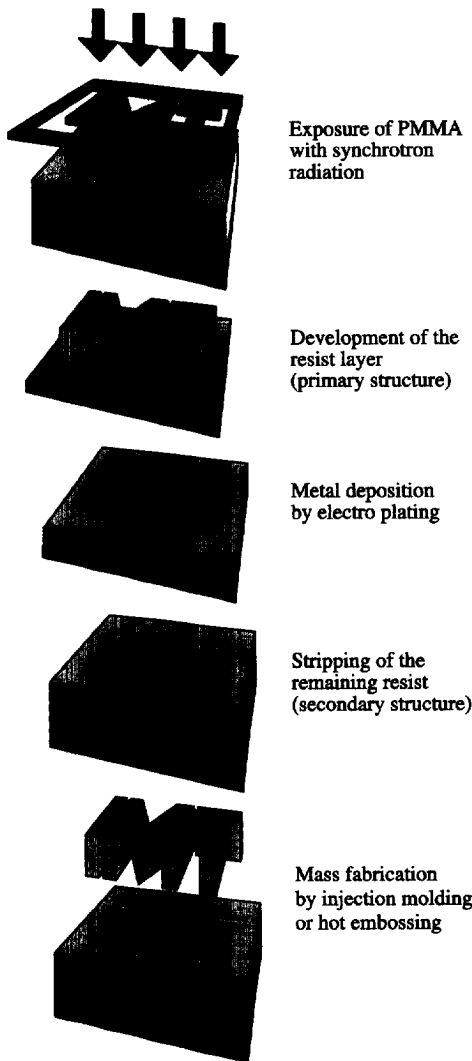

Fig. 1. Schematic process steps of the LIGA technology.

Two processes have been developed at the IMT for the fabrication of titanium mask blanks [3]. In the first process, titanium is sputtered onto a metallic substrate made from Invar. In order to obtain the desired stress in the titanium membrane, a precise annealing process must be applied. The free standing and stretched membrane is obtained by selective etching of a window into the backside of the substrate.

To be able to use silicon wafers as much cheaper substrates and to avoid application of an etchant, a transfer technique for titanium mask blanks has been developed (see Fig. 2). In the first step, a silicon wafer is covered with a 100-nm-thick low-adhesive carbon layer. At the edge of this wafer a 3 mm wide margin is left uncovered. In the next step, titanium is sputtered onto the carbon layer. Subsequently, a frame is glued to this layer system and the titanium layer outside the frame is cut by mechanical scribing. The separation of the frame-foil combination from the wafer is performed by bending the wafer carefully in a specially designed apparatus and to lift off the mask blank. The carbon remaining on the titanium foil is stripped by an oxygen plasma in a barrel reactor.

This mask blank is spin coated with a resist layer of 3- to 4- μm thickness. Subsequently, the resist is patterned by

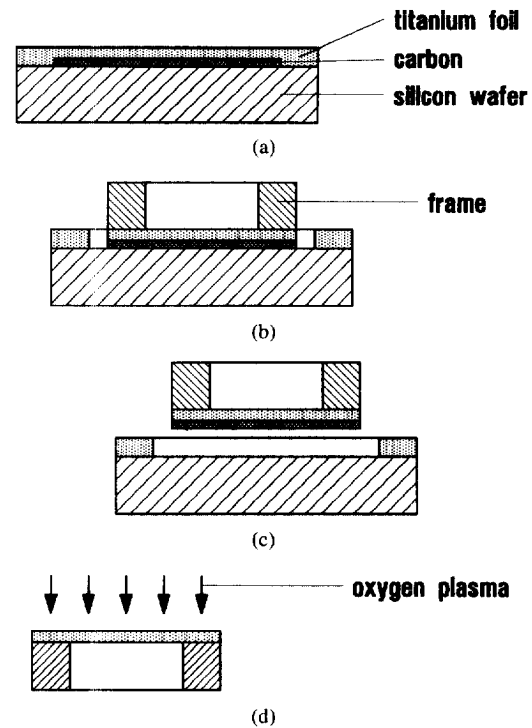

Fig. 2. Schematic process steps of the transfer technique for mask blank fabrication.

electron beam lithography. In the following electroforming process, the absorber structure is generated in gold onto the mask blank. Unfortunately, due to the low resist thickness, the metal deposition is limited in height to about 2 μm , thus resulting in a low X-ray contrast. Therefore this mask is used only as an intermediate product for the further manufacturing of a "working mask." By means of soft synchrotron radiation of about 2-nm wavelength, the lateral information of the intermediate mask is copied into a mask blank with a cast resist layer of about 20- μm thickness. This is done without measurable loss in lateral resolution. Again, a gold electroforming process is applied to form the final absorber structure which is then used as the working mask with the required high contrast for X-ray radiation [4].

For the alignment of these working masks with respect to any structural information on the substrate, alignment windows have to be worked into the titanium carrier foil of the working mask [5]. No distortions could be found that were due to the opening of an alignment window if a gold rim around the window was applied to support the membrane (see Fig. 3).

B. X-Ray Lithography

The absorber pattern of a mask is transferred into a resist layer of up to more than 1000- μm thickness by X-ray lithography using synchrotron radiation. Irradiation of the resist causes the long polymer chains to be cracked. Thus the molecular weight of the polymer is reduced by a process depending on the nature and energy of the incident radiation [6].

By means of a suitable developer, the fractions of lower molecular weight are dissolved, leaving behind the intact molecular chains of the unirradiated areas. The developer has

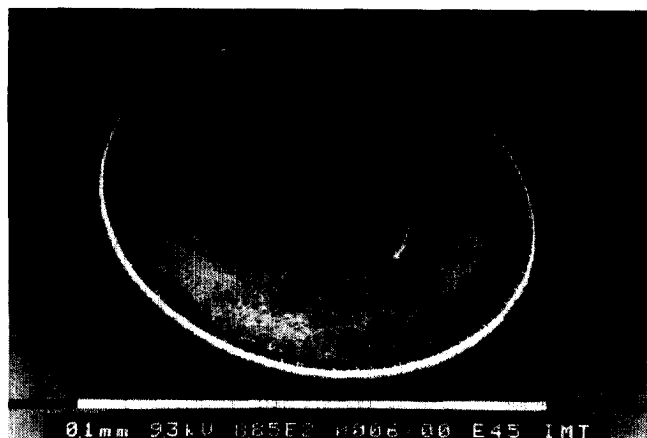

Fig. 3. Alignment window made of electroplated gold with $1 \times 1 \mu\text{m}$ bars and $40\text{-}\mu\text{m}$ inner diameter.

to fulfill certain requirements such as not to penetrate the unirradiated areas and causing swelling or even attacking those structures by dissolving unirradiated areas. Otherwise it would lead to structural distortions and edge roundings. This is of particular importance in the development of structures with high aspect ratios such as deep trenches where the upper edges of the structure are exposed much longer to the developer than the bottom of the trench.

A developer which is well suited for PMMA is a mixture of ethylene glycole monobutyl ether, monoethanolamine, tetrahydro-1,4-oxazine, and water [7].

C. Electroplating

The microstructures manufactured by means of X-ray lithography and consisting of plastic, most frequently PMMA, may be the end product in some cases, e.g., microoptical components. However, in many cases, metal microstructures are needed, which are manufactured by replacing the exposed and dissolved plastic with metal through electrodeposition. Using these metal microstructures as mold inserts for a cost effective injection molding, the LIGA technique is qualified for industrial mass production. In principle, microstructures can be manufactured by the LIGA technique which consists of any metals and alloys amenable to electrodeposition. However, as particular requirements must be made on the electrolytes used in the LIGA technique, extensive development work is necessary to supply the LIGA microstructures with a variety of pure metals and alloys alike.

Nickel is a standard material for electrodeposition within the LIGA technique. Nickel deposition is a well-controlled process, and the material exhibits high tensile strength and good resistance against corrosion. The standard electrolyte is a nickel sulfamate bath, the current density is kept to 1.8 A/dm^2 to achieve low internal stress of the deposited nickel at high hardness [8]. After the electroforming process, the remaining polymer is stripped and the exposed plating base is removed by wet chemical etching.

Magnetic microactuators, e.g., from NiFe alloys like PERMALLOY (80–82 wt% Ni) are of particular interest, if they can be manufactured by electroforming within the

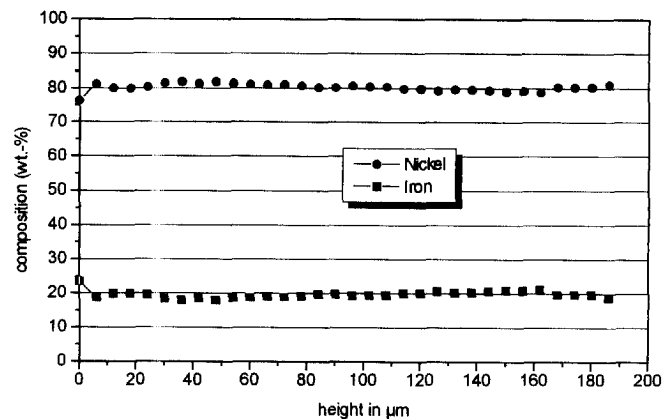

Fig. 4. Composition gradient over the height of a honeycomb shaped LIGA microstructure from PERMALLOY measured by EDX.

framework of LIGA. In this case, the NiFe alloy has to be deposited into the complementary polymer (resist) microstructure with homogeneous composition over the structural height of up to several hundred microns. A special difficulty is to preserve a constant alloy composition in complicated structures with different lateral geometries and aspect ratios.

Microstructural devices from PERMALLOY with a maximum height of $200 \mu\text{m}$ and of various shapes (honeycombs, prisms, columns, coils, and tubes with aspect ratios up to 20, respectively) were manufactured by electroforming [9]. The concentration of Ni and Fe in the alloy was determined by energy dispersive X-ray analysis. Fig. 4 shows the composition gradient versus the structural height of a single column with a diameter of $5 \mu\text{m}$ and a height of $90 \mu\text{m}$. The Fe content increases from the bottom to the top of the column from 19–22 wt.-%, and correspondingly the Ni content decreases from 81 to 78 wt.-%. All the microstructures tested showed this composition gradient regardless of their aspect ratio.

The magnetic properties were measured using a vibrating sample unit with a SQUID-detector. The coercivity was determined to be less than 10 Oe and the saturation moment was approximately 1200 G. The determined grain size was smaller than $1 \mu\text{m}$. Obviously, the magnetic properties of these PERMALLOY microstructures are superior to those of nickel microstructures of the same geometry manufactured by electroforming from a nickel sulfamate bath. Nickel prisms show a coercivity of 80 Oe, and a saturation moment of 680 G.

D. Plastic Molding

In the preceding sections, the techniques have been described for the manufacture of a primary structure in PMMA or of a complementary metal structure by means of electrodeposition. The LIGA technique is of interest to commercialization on an industrial scale, especially by the possibility that it provides the possibility of replication through injection molding, reaction injection molding, or vacuum embossing, i.e., typical techniques lending themselves to mass production [25]. By the molding techniques optimized for the LIGA technique, even

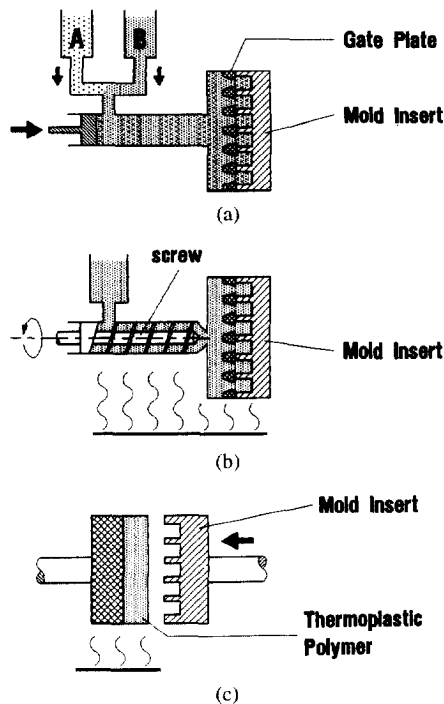

Fig. 5. Schematic representation of the LIGA molding technology. (a) Reaction injection molding. (b) Thermoplastic injection molding. (c) Embossing.

microstructures having high aspect ratios can be molded in high quality. The basic process steps are sketched in Fig. 5.

A novel concept for plastic molding of microstructures is particularly suited for molding microstructures on processed silicon wafers, i.e., on top of microelectronic circuits.

The Quasi-Monolithic Integration with Microelectronics: Previous investigations had made evident that building up LIGA microstructures on CMOS circuits using X-ray lithography is difficult, since the CMOS circuits might get heavily damaged by high energy radiation. Therefore, in order to fabricate LIGA microstructures directly onto integrated circuits, a molding process seems to be a suitable method with regard to compatibility and fabrication costs as well. In addition to the development of the molding techniques for single microstructures, concepts and techniques are being worked out to fabricate complex subsystems or even full microsystems by means of molding.

In the following, the process steps of hot embossing and the material parameters are briefly described. High attention was given to the compatibility of this process to CMOS microelectronics. Compatibility tests were performed to prove the feasibility of this integration technique for industrial application.

In Fig. 6, the principle of this integration process is shown. In order to protect the integrated circuits, a protective coating is applied. After that, a conductive film is applied as a plating base for subsequent processes. Onto this conductive film a double layer of differently prepared PMMA is applied. The bottom layer contains an internal adhesion promoter to provide good adhesion to the protective layer of the wafer, whereas in the upper layer, a mold release agent is included to ensure an easy separation from the molding tool [10].

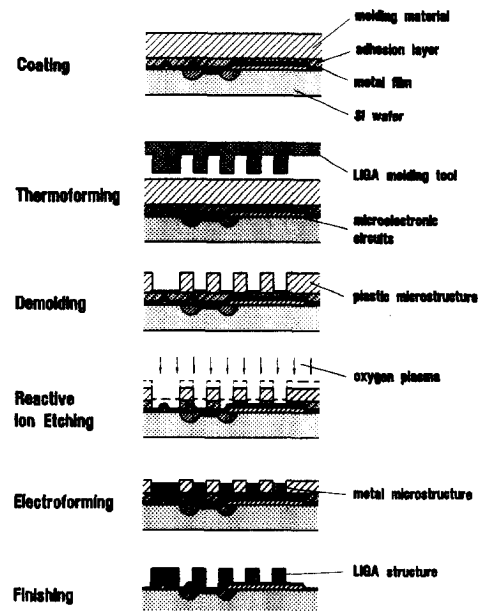

Fig. 6. Process steps of the quasi-monolithic integration of LIGA microstructures and microelectronic circuits.

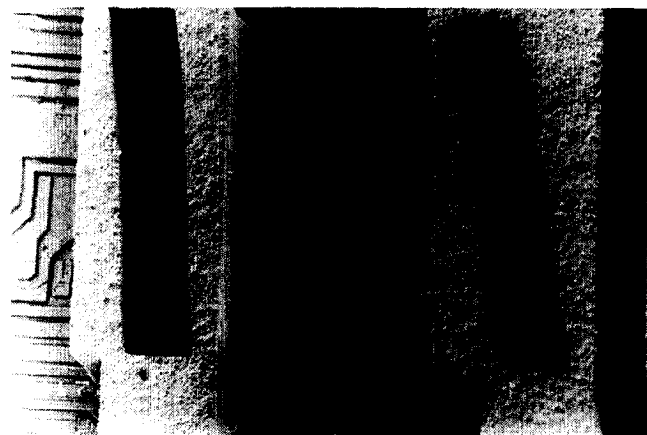

Fig. 7. SEM photograph of a nickel LIGA microstructure manufactured by vacuum embossing and electroplating on top of a CMOS device.

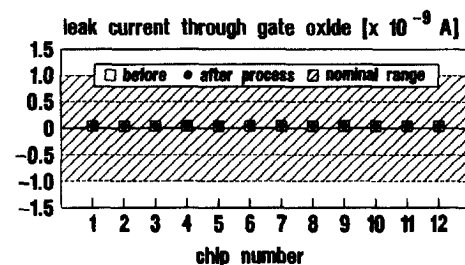

Fig. 8. Results of test measurements on CMOS test circuits before and after vacuum embossing, RIE, and nickel electroplating processes.

The polymer is heated beyond its glass transition temperature and structured under vacuum by impression of the molding tool. After cooling down, the microstructures can be demolded from the tool.

After demolding, a thin residual layer of the adhesion layer is left at the base of the microstructures. This polymer

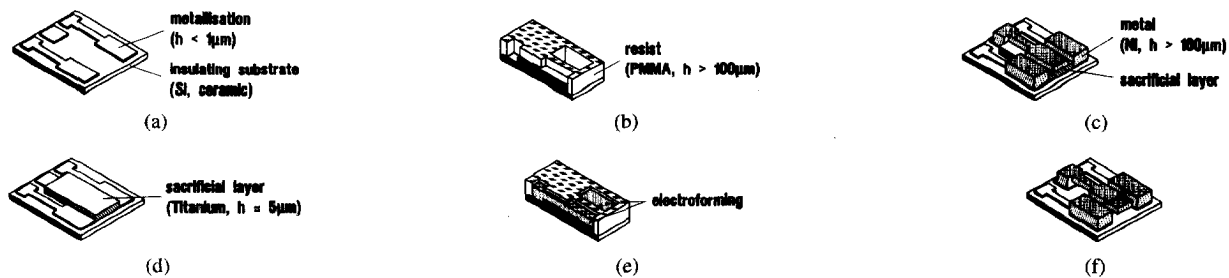

Fig. 9. Schematic representation of the sacrificial layer technique within the LIGA process.

layer is removed by Reactive Ion Etching in an oxygen plasma to uncover the conductive film for the following electroforming process. An anisotropic plasma is used where structural (lateral) loss is due only to small fractions of undirected oxygen radicals and secondary effects. With the removal of the 20- μm residual layer, each side wall is etched for 0.4 μm . The etchant selectivity of 1:50 has to be taken into account in the design phase already.

The conductive film serves as a plating base when contacted as a cathode and the metal structure is electrodeposited. Finally, the molding material and the adhesion layer is stripped in a solvent and any sacrificial or auxiliary layers are removed. Fig. 7 is an SEM picture of a LIGA structure in nickel on top of a CMOS test circuit.

Using this technique with the given parameters, compatibility tests along the entire process line were performed. It was possible to demonstrate that the single process steps do not change the electronic performance of the CMOS circuits by checking test circuits before and after the process steps as can be seen in Fig. 8.

The use of molding techniques opens the path to microsystem manufacturing by combining two different technologies (LIGA and CMOS) on one single substrate in quasi-monolithic integration.

As the molding technique to manufacture movable microstructures can be combined with positioned molding, it will be possible to generate movable microstructures functionally connected with the CMOS circuits on a processed silicon wafer without impairing the integrated circuits. This will be a considerable progress in microsystem manufacturing as movable microstructures (sensors and actuators) will be able to interact with the integrated circuits lying underneath.

III. MODIFICATIONS AND EXTENSIONS OF THE LIGA TECHNIQUE

A. The Sacrificial Layer Technique

To build up a microsystem, microcomponents are essential which can be used as sensors or actuators [11]. In many cases, this requires mobile microstructures, such as acceleration sensors, microvalves, or motors.

The LIGA technique allows the fabrication of mobile microstructures by introduction of sacrificial layers (see Fig. 9). This has considerably extended the application of the LIGA technique because, also, a wide range of materials and a great structural height are available for building optimum sensors

and actuators and almost no limitations are imposed on the lateral shape with respect to molding processes.

Titanium has proved to be the best suited material for the sacrificial layers in the LIGA technique because, on the one hand, it adheres well to the resist and electrodeposited layer and, on the other hand, it can be etched with hydrofluoric acid which does not attack the materials (Cr, Ag, Ni, Cu) normally used in the LIGA technique. The titanium layer should be sufficiently thick so that the mobile structures are at adequate distance from the substrate. The titanium layer is shaped in such a way that the mobile parts of the microstructure are built up over the titanium layer, whereas the stationary parts are placed directly on the plated layer. In a last process step the titanium sacrificial layer is etched selectively against the rest of metals and materials, respectively.

B. Microstructures with Different Level Heights

For the increasing number of microstructural applications, more complex geometries with variably formed steps are of special interest [12]. Within the framework of the LIGA process, our development activities therefore aim at making available a technology, which allows the fabrication of vertical and inclined side walls, as well as of stepped structures with a variable geometry.

On the basis of the combination of deep-etch X-ray lithography and electroforming, a process for the fabrication of two- or multi-step microstructures has been developed. Starting from a first X-ray mask, a single-step resist structure is fabricated by means of lithography. Subsequent electroforming results in a metal mold insert. This mold insert is then used to pattern the upper surface of a resist layer in a vacuum molding process. During subsequent lithography, structurization of the bottom surface of the resist layer is carried out using a second X-ray mask. The two-step resist obtained is then employed to fabricate a mold insert by electroforming which can be applied for the molding of two-step structures.

In Fig. 10, a SEM of a two-step PMMA test structure fabricated by means of molding and lithography is represented. The total structural height amounts to about 340 μm with the first step being about 100 μm .

For the molding of simple as well as stepped microstructures, not only the known PMMA but also fluorinated polymers are of particular interest. Compared to PMMA, fluorinated polymers are characterized by a better resistance to chemicals and higher operating temperatures. Furthermore, the components must not release impurities when being used.

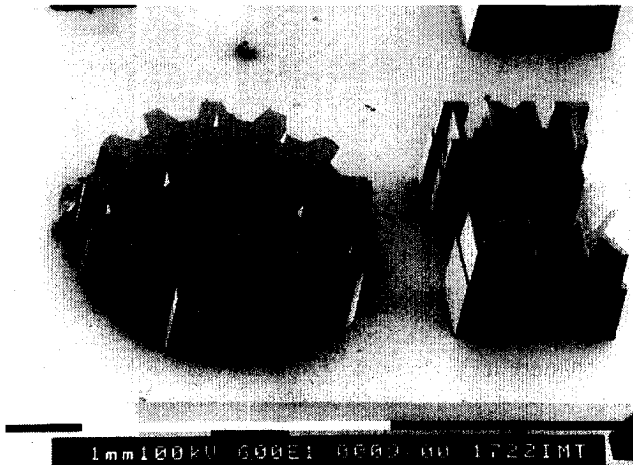

Fig. 10. SEM photograph of a stepped LIGA microstructure from PMMA.

This problem sometimes occurs with plastic containing mold release agents. Under certain circumstances, the favorable friction and sliding properties of fluorinated plastics can be made use of for correct molding of plastic microstructures, even without mold release agents.

IV. MICROSTRUCTURES IN LIGA TECHNIQUE

A. Examples of Optical Structures in PMMA

The PMMA resist used in the LIGA technique has good optical transmission properties in the visible range and in the near infrared. Therefore the so-called "primary structures" manufactured from PMMA can be used in a variety of optical applications [13], [14]. This necessitates a surface roughness of the imaging planes of approximately one tenth the size of the wavelength of the light used. By phase shifting interferometry, it has been demonstrated that the roughness of the lateral walls generated by X-ray lithography is on the order of 30–40 nm which means that the major prerequisite of optical applications can be satisfied. It is also possible to manufacture microoptical components by cost effective molding techniques. Besides PMMA, other plastics can be used which might exhibit favorable features in special applications.

In order to reduce the divergency induced losses in vertical direction of light transmitting structures, a special three-layer resist system has been developed. It consists of a light-conducting core layer and two sheathing layers with a lower refractive index than the core layer. Thus, the light is guided in the core layer due to total reflection at the boundary layers. PMMA has been chosen for the core layer and a copolymer made of PMMA and tetrafluoropropyl methacrylate (TFPMA) as the sheathing layer.

Grating spectrographs for multi-mode applications are normally fabricated in hybrid technology using, for example, a waveguide made of an accurately shaped glass to which a reflection grating must be mounted precisely [15]. The grating is usually fabricated by high precision mechanical shaping or by holographic technique. The light is coupled into the spectrometer by a fiber precisely adjusted to the grating. Both

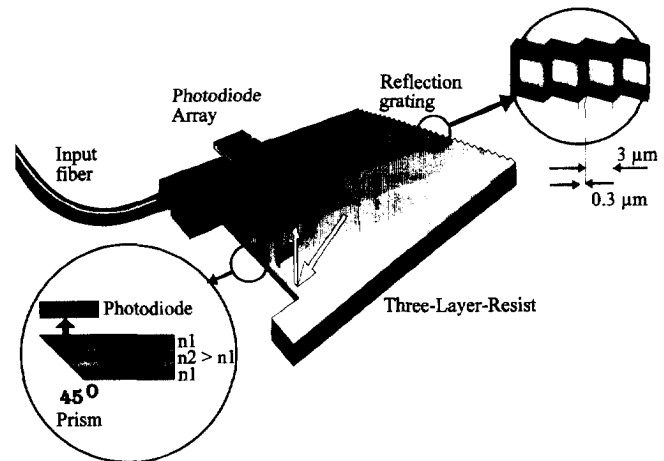

Fig. 11. Principle layout of a grating spectrograph with self focusing reflection grating fabricated by deep-etch X-ray lithography. The spectral light can be detected either by several fibers or by a diode array.

methods are very cost-intensive steps within the fabrication process.

By producing the grating of the spectrometer jointly with the fiber coupling trench and integrated with an array of photodiodes, it is possible to reduce the production costs as well as the volume of these grating spectrographs. This is possible by patterning a three-layer resist system by deep-etch X-ray lithography, which is the first step of the LIGA process [16].

The three-layer resist system is fabricated by welding polymer foils, which were polymerized from the monomer onto a polymer base-plate made of an epoxy-phenol resin. Using this substrate material, which is insensitive to X-ray radiation, the thermal expansion coefficient of the base plate is well adapted to the resist material to reduce tensile cracking. The first layer of the three-layer resist is polymerized directly onto the chemically activated epoxy phenolic plate and machined down to a thickness which corresponds to the thickness of the cladding of the optical fibers. Subsequently, a PMMA foil is welded onto this first layer and adapted by milling to the thickness of the fiber core. Finally, a cover foil is put on top of this sheet system. It serves as the top cladding layer of the light guiding assembly.

The polychromatic light which is injected into the waveguiding component by an optical fiber is dispersed at the grating which is coated by gold or silver and reflected toward the focal line. The spectrally divided light can be coupled out at the focal line by several optical fibers. On the other hand, it is also possible to pattern an inclined sidewall by X-ray lithography [16], [17] where the direction of the light is changed from the horizontal to the vertical plane by internal reflection. This opens up the possibility to mount the grating spectrograph on top of a diode array, which will be used to detect the different spectral parts of the light. The principle layout of a grating spectrograph with self focusing reflection grating and a diode array is shown in Fig. 11.

To determine the quality of the components, light from a monochromator was fed into the spectrometer. The intensities at the output were measured as a function of the wavelength

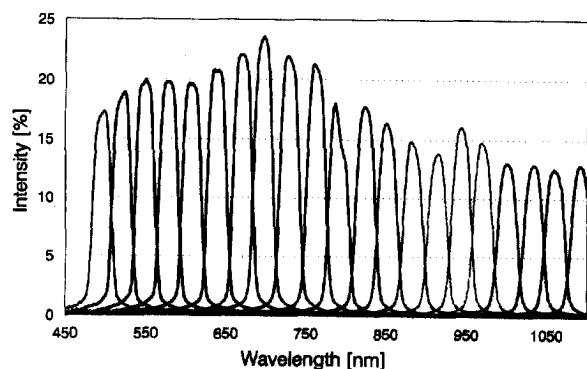

Fig. 12. Calculated intensity distribution of a grating spectrograph blazed to 740 nm and working in the first order. As a detector, a glass fiber with an outer diameter of 125 μm and a core diameter of 85 μm has been used.

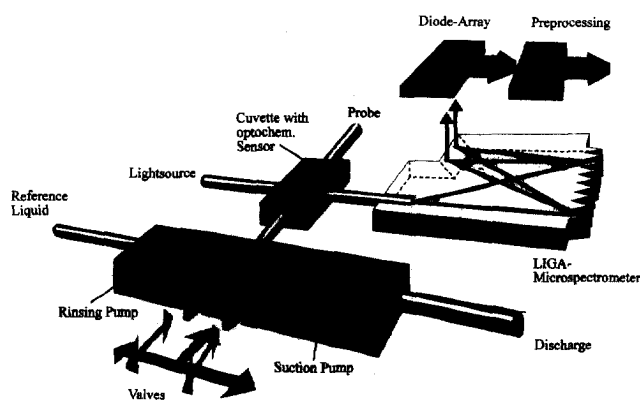

Fig. 13. Principle of a complete analysis system which combines the spectrometer with fluid handling components, optochemical sensors, and electronics.

using a multi-mode fiber as a detector. The fiber was positioned in a trench at the focal line, whereas the different positions of the fibers had a distance of 125 μm . The detected intensities were related to the intensities measured without the components with two butt coupled fibers. Fig. 12 shows the results of these measurements for the grating spectrograph which was designed to work in first order and blazed to 740 nm.

The described grating spectrographs are well suited for use in spectroscopic analysis in the visible and near infrared region which lends itself to many applications. These include, e.g., examinations in the environmental area like detection and analysis of different heavy metal ions in water or toxic agents in smoke. They can also be used in medicine to detect, e.g., the oxygen content in blood. In Fig. 13, the principle of an analytic system is shown which combines the spectrometer together with fluid handling systems, optochemical sensors, and electronics.

B. Examples of Flexible and Rotatable Structures

With the help of the sacrificial layer technique, microstructures which are suspended from the substrate either partly or fully can be manufactured in one single sequence of processes. These mobile microstructures have considerably extended the number of applications of the LIGA technique because this offers a means of sensor and actuator manufacture.

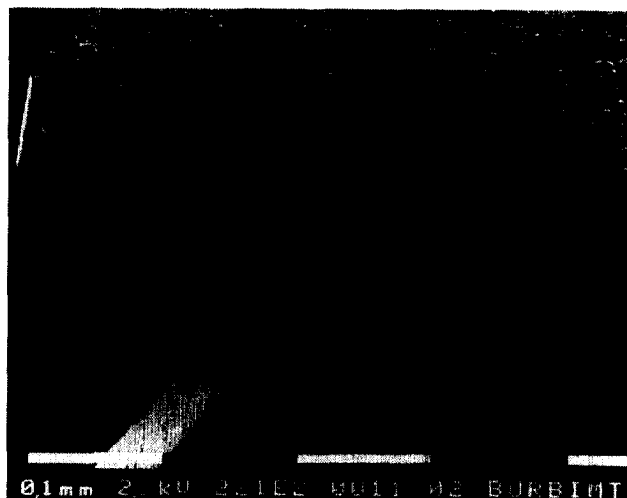

Fig. 14. SEM photograph of a LIGA acceleration sensor (first design) manufactured from nickel by electroforming.

Acceleration Sensors: The first mobile LIGA structure manufactured by means of the sacrificial layer technique has been an acceleration sensor [18]. The basic features of the acceleration sensor fabricated by this process can be seen from Fig. 14.

Acceleration measurement is important in a wide range of commercial applications. Especially in automotive engineering, there are different applications of acceleration sensors, e.g., to enhance the safety of the passengers or to control the movement of the chassis. All these applications demand inexpensive mass fabrication processes.

A seismic mass suspended by a cantilever which was fabricated on the sacrificial layer is able to move between two stationary electrodes firmly attached to the substrate. The change in capacitance between the seismic mass and the electrodes can be measured.

The static behavior of the acceleration sensor was examined by tilting the sensor in the acceleration field of the earth and by measuring the change in capacitance with a commercial Wheatstone bridge.

For the examination of the dynamical behavior the sensor was accelerated by a sinusoidal force with different frequencies at atmospheric pressure. The observed high resonance setup indicates a low damping of the sensor at atmospheric pressure. This is caused by the slits perpendicular to the capacitor gap (see Fig. 14). By changing the geometry and the numbers of these slits, it is possible to vary the resonance response.

In order to reduce the temperature influence on the accelerator, a special temperature compensation design was introduced, which is shown in Fig. 15. Instead of a solid seismic mass, a fork-like structure is suspended by two cantilever beams. The stationary electrodes are divided into inner electrodes with a negative temperature coefficient (T_c) and outer electrodes with positive T_c . If the seismic mass expands due to temperature increase, the gap between the seismic mass and the electrodes will either decrease or increase. By connecting the electrodes to a bridge circuit the temperature dependence (Temperature Coefficient of Offset, TCO) can be minimized to only 1.02×10^{-4} g/K [19].

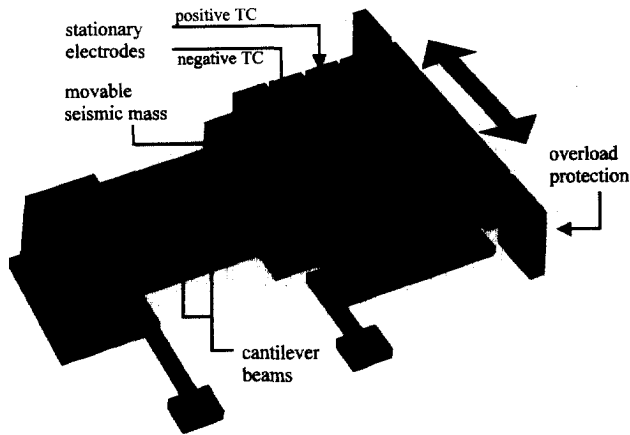

(a)

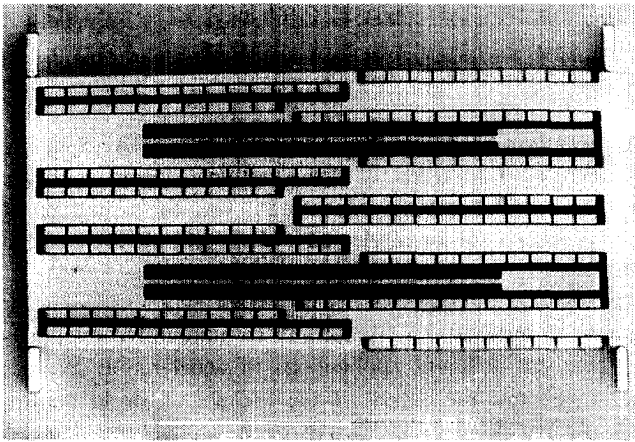

(b)

Fig. 15. (a) Principle design of a temperature compensated LIGA acceleration sensor and (b) SEM photograph of a temperature compensated LIGA acceleration sensor manufactured from nickel by electroforming.

Microturbine: By contrast, in rotating microstructures the rotor must be fully detached from the substrate whereas the axle remains rigidly connected to the substrate [20]. The first rotating LIGA structure manufactured has been a microturbine which is driven by gases or liquids. Fig. 16 shows a microturbine made of nickel with a diameter of $130\ \mu\text{m}$ which is less than the height of $150\ \mu\text{m}$. The gap between the rotor and the axle in this case is only $5\ \mu\text{m}$. The speed of microturbines can be measured via a glass fiber laid into a prefabricated duct and illuminating the rotor. At the front faces of the rotor blades, the light is reflected back into the same fiber, and by counting the light pulses, the speed can be determined with high accuracy. In this configuration, the microturbine could be used as an actuator and as a flowmeter as well.

Micromotors: If the rotor and stator of a motor are equipped with electrodes partly displaced relative to each other, the tangential propulsion component can be exploited to generate, respectively, a torque and a rotation. After the plate displacement has been balanced out and the tangential force has disappeared, a voltage is applied to the adjacent pair of electrodes which, in turn, are displaced relative to each other. The resultant torque increases linearly with the height of the

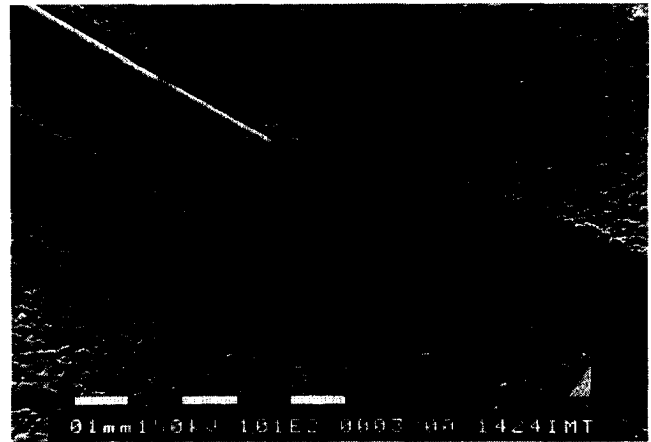

Fig. 16. SEM photograph of a LIGA microturbine from nickel with integrated glass fiber for velocity measurement.

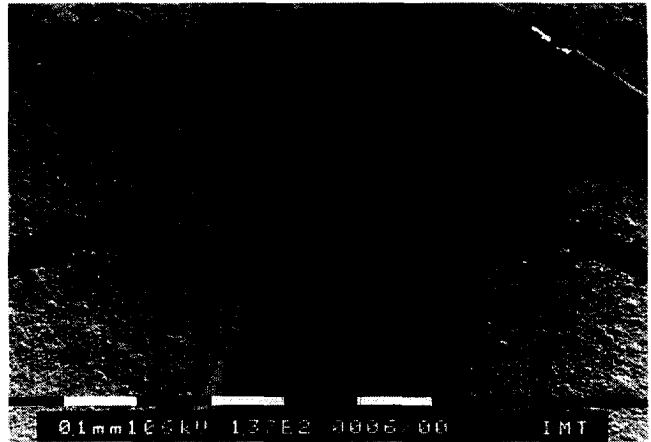

Fig. 17. SEM photograph of a LIGA micromotor manufactured from nickel by electroforming.

structure; consequently, electrostatic micromotors should have large structure heights, which can be achieved well with the LIGA process. Since the tangential propulsion force in a plate capacitor is a function of the height but not of the length of the plates (electrodes), the rotor and the stators are best designed as a multitude of small plates connected in parallel which, eventually, produce a serrated surface. This design can be seen in the SEM micrograph in Fig. 17, which also demonstrates the large structure height of $120\ \mu\text{m}$.

In addition to rotating micromotors, linear motors have been fabricated and successfully tested [21], [22]. These different electrostatic motors can be used as microactuators in complex microsystems. In one example, developed at FzK, an electrostatic micromotor connected to a small mirror is used to switch rays of light off and on. It is planned to use such a microactuator in optical communications systems.

C. Examples of Fluidic Components

Micropumps: Micropumps are fabricated by combining the LIGA process or conventional micromachining, and a membrane technique [23], [24]. A photograph of the membrane micropump is shown in Fig. 18.

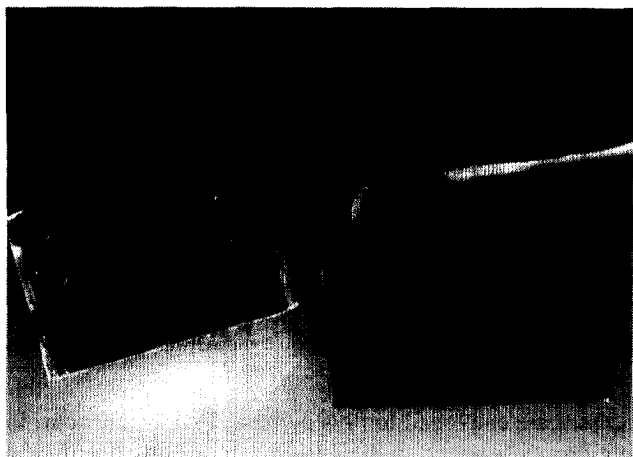

Fig. 18. Photograph of micropump manufactured by a combination of LIGA technique and membrane processes.

The case of the pump consists of two thermoplastic parts with a single polyimide membrane mounted in between. The actuator chamber, pump chamber, flow channels, and valve seats are patterned into the two parts of the pump case. The movable parts of the pump, such as the pump membrane and valve membranes, are integrated into a single polyimide membrane 1- μm thick. A gold meander 2- μm thick on top of the membrane is used for electric heating of the air in an actuator chamber. The pressure rise closes the inlet valve, while the outlet valve opens and the air is forced out.

In the first step, the two parts of the pump case and the polyimide membrane with the titanium heater were manufactured separately. In the second step, the completed and tested components were bonded by an adhesive bonding technique. The cases of 12 pumps were molded in parallel from polyvinylidene fluoride (PVDF) or polysulfone (PSU) by vacuum hot embossing and injection molding, respectively. The polyimide membrane was manufactured on a silicon wafer and patterned photolithographically. The gold layer was sputtered onto the polyimide and patterned by photolithography and etching. The two parts of the pump case and the polyimide membrane were joined by adhesive bonding. This pump is being fabricated in a small scale fabrication and will be available on the market.

It has been demonstrated that gases in addition to liquids can be transported by these micropumps. This greatly expands the number of applications relative to other known micropumps, most of which can only pump liquids. The micropump was used to pump air out of a closed vessel, and the pressure drop was recorded. A maximum flow rate of ca. 300 $\mu\text{l}/\text{min}$ and a maximum pressure reduction by 130 hPa were attained.

Such micropumps will be essential parts of complex fluid handling systems which are necessary to deliver very precisely small amounts of fluids to microchemical sensors. Potentially, microsystems containing micropumps may also be implanted to precisely meter and deliver drug doses to a patient.

V. THE CONCEPT OF AN "INTELLIGENT" SENSOR SYSTEM

All this applies to micropatterns. On a laboratory scale, the production of micropatterns is now under control in principle,

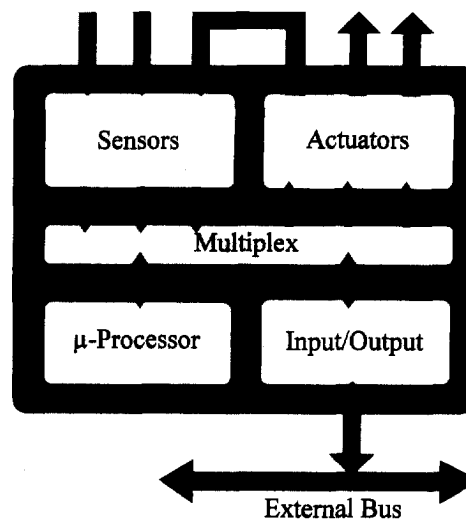

Fig. 19. Principle layout of a microsystem.

even though new variants of the process technology keep coming up, thus continuously expanding the spectrum of microengineering. However, all these components will be of limited interest only, unless microsystems can be designed and made. The resounding technical success of microelectronics is not due to the continuous size reduction of electronic components, such as transistors, but to the successful production of systems in which the performance of each individual element was enhanced by several orders of magnitude. In other words, it was only the development of microprocessors which initiated the success of microelectronics. A similar development must take place in micropattern engineering, unless one is satisfied with replacing conventional components by those made by micropattern techniques. As in microelectronics, "microprocessors" must be designed for nonelectronic applications. What should such a microsystem be like?

Fig. 19 shows the basic principle of a microsystem. We recognize a "sensors" subgroup, an "actuators" subgroup, a data processing stage with the necessary periphery and, finally, an "input/output" module. Let us briefly characterize these subgroups.

A. Sensors

Micropattern engineering allows an array of many sensors instead of just one to be incorporated in a system, as the expense is not much greater, thanks to photolithographic transfer. Instead of one measurement, a large number of measurements thus can be conducted in parallel. The flow of measured data can be evaluated in the computer connected downstream. If, in an array of n sensors, one sensor were to fail because of a defect, $n - 1$ sensors would still be functioning. The advantage of a sensor array lies in the possibility to average over many parallel measured data, and in the increased protection against defects or failures of individual sensors. Arrays may combine sensors of different sensitivities; irrespective of the amplitude of the actuating quantity, at least one sensor thus is always in the ideal range of sensitivity.

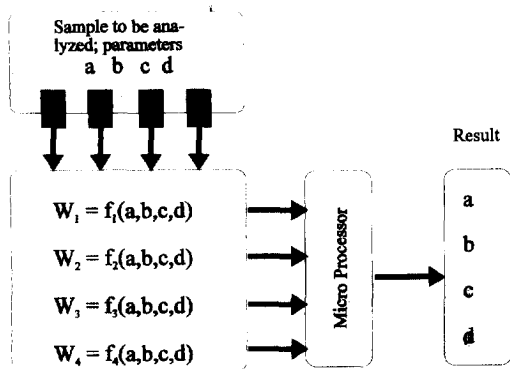

Fig. 20. Principle layout of a sensor array as part of a microsystem.

Sensors, especially chemical sensors, can be installed in an array also with different selectivities and cross-sensitivities. The general case is shown in Fig. 20; it indicates that, in the case of sensors whose cross-sensitivity is known, the measurement problem reduces to the solution of a system of equations. Such a system has a high selectivity, low measurement error, and can be upgraded for application to various problems.

B. Actuators

The actuators in a microsystem carry out certain manipulations controlled by sensors; in measurements of physical parameters (such as acceleration), they can considerably extend the dynamic range of a sensor by active feedback and, finally, they can make the whole microsystem mobile. In this way, applications can be achieved in which the microsystem independently addresses measuring stations and automatically conducts measurements, or in which the system can penetrate into very small rooms difficult to enter, or hazardous rooms, for exploration and manipulation.

C. Data Processing

In addition to their key activity of evaluating sensor data, computers are employed to execute functional tests, for self-monitoring purposes, self-correction, or for the management of redundant subsystems. In all safety-related activities, such as transport systems, process control, environmental monitoring, or medical technology, this property of an intelligent microsystem is of fundamental importance.

D. Interfaces

One important feature of a microsystem is its ability to communicate with persons, with some other, equivalent microsystem, or some higher-level computer. Besides this "classic" purpose of a data interface, which is defined as in microelectronics, a microsystem has numerous micro-macro interfaces. Each microsystem functions in a macroscopic environment. Consequently, there are interfaces, for instance to transmit optical, mechanical, acoustic or fluidic energy. To the usual data interfaces must be added a number of variants because, for instance in implants in medical technology, data must be transferred "transcutaneously," i.e., in a noninvasive way through the skin. Optical, acoustic, magnetic, and electric

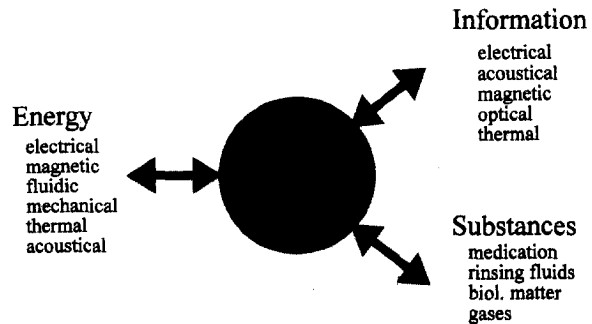

Fig. 21. Principle sketch of a microsystem equipped with various interfaces.

processes are employed for this purpose. Finally, the actuating quantities must be fed to the sensors with as little falsification as possible. This, too, must be considered an interface. In a microendoscope, also, matter must be transferred into or out of the microsystem, for instance rinsing liquids, drugs, and the like. Fig. 21 is a graphic representation of the importance of the micro-macro interface.

The above discussion of the subsystems clearly indicates that a microsystem must be much more powerful than the sum total of its components. So, once microsystems become available commercially instead of single components, the potential for applications is going to multiply also. Indeed, it is to be expected that microsystems engineering will catch up with, or even surpass, microelectronics in terms of technical and economic importance. Potential areas of application range from automotive engineering through process control, communications engineering, and building installations to environmental technology and medical technology. Many areas of application have not yet been considered even theoretically; certainly, the future in this field is going to produce a number of surprises. Twenty years ago, who would have thought that personal computers could ever become an important area of application of microelectronics?

REFERENCES

- [1] E. W. Becker, W. Ehrfeld, P. Hagmann, A. Maner, and D. Münchmeyer, "Fabrication of microstructures with high aspect ratios and great structural heights by synchrotron radiation lithography, galvanofarming, and plastic molding (LIGA process)," *Microelectron. Eng.*, vol. 4, p. 35, 1986.
- [2] M. Harmening and W. Ehrfeld, "Untersuchung zur Abformung von galvanisierbaren Mikrostrukturen mit großer Strukturhöhe aus elektrisch leitfähigen und isolierenden Kunststoffen," *KfK-Bericht 4711*, 1990.
- [3] W. K. Schomburg, P. Bley, H. Hein, and J. Mohr, "Masken für die Röntgentiefenlithographie," *VDI Berichte*, vol. 870, p. 133, 1990.
- [4] W. Bacher, P. Bley, H. Hein, U. Klein, J. Mohr, W. K. Schomburg, R. Schwarz, and W. Stark, "Herstellung von Röntgenmasken für das LIGA-Verfahren," *KfK-Nachrichten*, vol. 23, no. 2-3, p. 76, 1991.
- [5] W. K. Schomburg, H. J. Baving, and P. Bley, "Ti- and Be-X-ray masks with alignment windows for the LIGA process," *Microelectron. Eng.*, vol. 13, p. 323, 1991.
- [6] A. El-Kholy, P. Bley, J. Göttert, and J. Mohr, "Examination of the solubility and the molecular weight distribution of PMMA in view of an optimized system in deep etch X-ray lithography," *Microelectron. Eng.*, vol. 21, p. 271, 1993.
- [7] W. Ehrfeld, H. J. Baving, D. Beets, P. Bley, F. Götz, J. Mohr, D. Münchmeyer, and W. Schelb, "Progress in deep-etch synchrotron radiation lithography," *J. Vac. Sci. Technol.*, vol. B6, no. 1, p. 178, 1988.
- [8] S. Harsch, W. Ehrfeld, and A. Maner, "Untersuchungen zur Herstellung von Mikrostrukturen großer Strukturhöhe durch Galvanoformung in Nickelsulfamatelektrolyten," *KfK-Bericht 4455*, 1988.

- [9] A. Thommes, W. Bacher, K. Leyendecker, W. Stark, H. Liebscher, and C. Jakob, "LIGA microstructures from a NiFe alloy: Preparation by electroforming and their magnetic properties," in *Proc. 1985 Meeting Amer. Electrochem. Soc.*, New Orleans, LA, Oct. 11–12, 1993, vol. 94-6, p. 89, 1994.
- [10] A. Michel, R. Ruprecht, M. Harmening, and W. Bacher, "Abformung von Mikrostrukturen auf prozessierten Wafern," *KfK-Bericht 5171*, 1993.
- [11] W. Menz, "Microactuators in LIGA technique," in *Proc. 3rd Int. ISEM Symp. Applicat. Electromagn. Forces*, Sendai, Japan, Jan. 28–30, 1991.
- [12] M. Harmening, W. Bacher, P. Bley, A. El-Kholi, H. Kalb, B. Kowanz, W. Menz, A. Michel, and J. Mohr, "Molding of three dimensional microstructures by the LIGA process," in *Proc. IEEE, MEMS'92*, Travemünde, Germany, 1992, Cat. No. 0-7803-0497-7/92, p. 202.
- [13] J. Göttert and J. Mohr, "Grundlagen und Anwendungsmöglichkeiten der LIGA-Technik in der Mikrooptik," *KfK-Bericht 5153*, 1993.
- [14] J. Göttert, J. Mohr, and C. Müller, "Examples and potential applications of LIGA components in microoptics," in *Teubner Taschenbücher der Physik*, W. Ehrfeld *et al.*, Eds. Stuttgart: B. G. Teubner Verlagsgesellschaft, 1992.
- [15] H. W. Yen, H. R. Friedrich, R. J. Morrison, and G. L. Tansonan, "A planar Rowland spectrometer for fiber-optic wavelength demultiplexing," *Optical Lett.*, vol. 6, p. 639, 1981.
- [16] C. Müller and J. Mohr, "Microspectrometer fabricated by the LIGA process," *Interdisciplinary Sci. Rev.*, vol. 18, no. 3, p. 273, 1993.
- [17] P. Bley, "The LIGA process for fabrication of three-dimensional microscale structures," *Interdisciplinary Sci. Rev.*, vol. 18, no. 3, p. 267, 1993.
- [18] C. Burbaum, J. Mohr, P. Bley, and W. Menz, "Fabrication of electrostatic microdevices by the LIGA technique," *Sensors and Materials*, vol. 3, no. 2, p. 75, 1991.
- [19] M. Strohrmann, P. Bley, O. Fromhein, and J. Mohr, "Acceleration sensor with integrated compensation of temperature effects fabricated by the LIGA process," in *Proc. Eurosensors VII*, Budapest, Hungary, Sept. 26–29, 1993.
- [20] J. Mohr, C. Burbaum, P. Bley, W. Menz, and U. Wallrabe, "Movable microstructures manufactured by the LIGA process as basic elements for microsystems," in *Micro Syst. Technol. '90*, H. Reichl, Ed. Berlin: Springer, 1990, p. 529.
- [21] H. Kalb, B. Kowanz, W. Bacher, J. Mohr, and R. Ruprecht, "Electrostatically driven linear stepping motor in LIGA technique," in *Proc. Actuator '94*, Bremen, Germany, June 15–17, 1994, p. 83.
- [22] J. Mohr, J. Göttert, M. Kohl, and A. Müller, "Mikrooptischer Schalter als bypass-element in optischen Datennetzwerken," *KfK-Bericht 5238*, 1993, p. 71.
- [23] R. Rapp, P. Bley, W. Menz, and W. K. Schomburg, "Micropump fabricated with the LIGA process," in *Proc. MEMS'93*, Fort Lauderdale, FL, 1993, p. 123.
- [24] B. Büstgens, W. Bacher, W. Bier, R. Ehnes, D. Maas, R. Ruprecht, and W. K. Schomburg, "Micromembrane pump manufactured by molding," in *Proc. Actuator'94*, Bremen, Germany, June 15–17, 1994, p. 86.
- [25] R. Wechsung, "Mikrostrukturprodukte aus Metallen, Kunststoffen und Keramik," *Sensor Rep.*, vol. 1, p. 41, 1993.

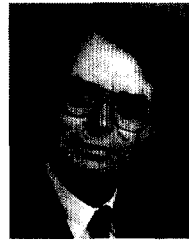

Walter Bacher was born in 1945 in Ohmden, Germany. He studied chemistry at the University of Stuttgart, Germany, and the University of Karlsruhe, Germany, where he received the Ph.D. degree in radiochemistry in 1970.

He was the leader of a group concerned with the development of fluorine chemistry and UF₆ technology within the framework of the separation nozzle process for the enrichment of uranium-235. After two years as an assistant to the board of directors of the Research Center Karlsruhe, he joined the

Institute of Microstructure Technology. He is currently head of the department for chemical technologies and plastic molding.



Wolfgang Menz was born in 1938 in Berlin, Germany. He studied physics at the University of Bonn, Germany, and the University of Hamburg, Germany. His Ph.D. thesis was on electron diffraction on alkalihalides.

He joined IBM in 1967, where he worked in Yorktown Heights, NY, and San Jose, CA, on electron beam lithography and magnetic bubble memories. He joined the Robert Bosch Company, Stuttgart, Germany, in 1979, where he was responsible for central research "Physics and Technology."

In 1989, he joined the University of Karlsruhe, Germany, where he is Director of the Institute for Microstructure Technology at the Research Center Karlsruhe.



Jürgen Mohr was born in 1957 in Ravensburg, Germany. He received the diploma in physics in 1983 and the Ph.D. degree in mechanical engineering with an emphasis in microsystem technologies, in 1987 from the University of Karlsruhe, Germany.

He has been with the Research Center Karlsruhe, Institute of Microstructure Technology, since 1987, as a research associate working in the field of X-ray lithography for microfabrication (LIGA process). Currently, he is head of a research group working in the development of high aspect ratio fabrication

processes. Beside process technology, his current interests are in the field of micromechanical sensors and actuators, as well as micro-optical structures.

Dr. Mohr is a member of LEOS.