

### MATLAB Problem

A mass,  $m = 2\text{kg}$ , is supported by a spring and a damper, as shown in the figure below. We want to analyze the motion of the mass when it is subjected to an initial displacement of 5 m and no initial velocity. Derive the equation of motion for the system. Then, use MATLAB to numerically integrate the equation for three different values of the damping constant. Try  $c = .5, 1,$  and  $5 \text{ N-s/m}$ . The force of a spring is given by  $F_s = kx$  where  $k = 5 \text{ N/m}$  and the force of a damper is given by  $F_d = c\dot{x}$ . *HINT: transform the 2<sup>nd</sup> order ODE into first order for use with ode45. There are example files on the website.*

Please turn-in your MATLAB code and three output plots of  $y$  vs.  $t$  for the three damping values.

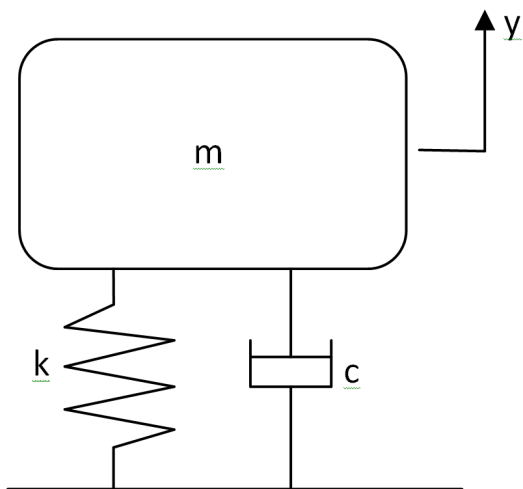

**Figure 1: Mass-Spring-Damper System**